



Confidex Ironside™

Technical Product Specification
Version 1.1
September 2008

Contents

1.	PRODUCT DESCRIPTION	2
1.1	SPECIFICATION DATA.....	2
1.2	DIMENSIONS	2
1.3	PERFORMANCE DATA	3
1.4	SUPPORTED COMPONENTS	4
1.5	SUPPORTED SERVICES.....	5
1.6	POSSIBLE APPLICATIONS	6
2	INSTALLATION INSTRUCTIONS	6
2.1	TAG PLACEMENT	6
2.2	TAG FIXING METHODS	7
3	ORDER INFORMATION	8

1. Product description

The patent pending solution of Confidex Ironside™ tag provides totally new benchmark for low-cost passive RFID in its size and durability (IP68) to various customer requirements. The tag can be mounted easily on any metallic surfaces either with industrial adhesive or mechanically e.g. with pop rivets. Ironside's performance enables several on-metal identification challenges to be solved which earlier where impossible with passive RFID. Ironside has passed the rigorous testing requirements for the Aerospace Standard AS5678 specification. It has been successfully used in tracking assets from steel pallets to train wagons.

1.1 Specification data

Device type	Class 1 Generation 2 passive UHF RFID transponder
Air interface protocol	EPCGlobal Class1 Gen2 ISO 18000-6C
Operational frequency	885-869 MHz (EU), 902-928MHz (US), 952-955 MHz (JPN)
IC options	NXP UCODE G2XM
EPC memory	up to 240 bit
EPC memory content	Unique number encoded as a default
Extended memory	512 bit
Read range	up to 6-7 m / 20-23 ft, reader power 2W ERP (dependent on application)
Applicable surface materials	Metal surfaces
Encapsulation material	Dark grey thermoplastic elastomer
Weight	22 g
Delivery format	Single
Amount in box	500 pcs (default)
Standard compliancy	SAE AS5678
Product is RoHS compliant	

1.2 Dimensions

General dimensions 51.5 x 47.5 x 10.0 mm / 2.03 x 1.87 x 0.39 in
(Width x Height x Thickness)

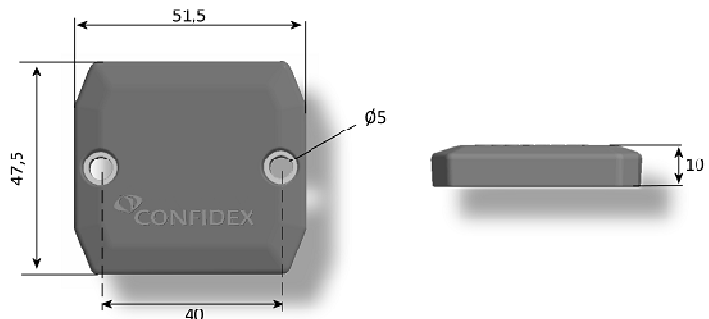

1.3 Performance data

Electrical performance

Ironside
NXP G2XM

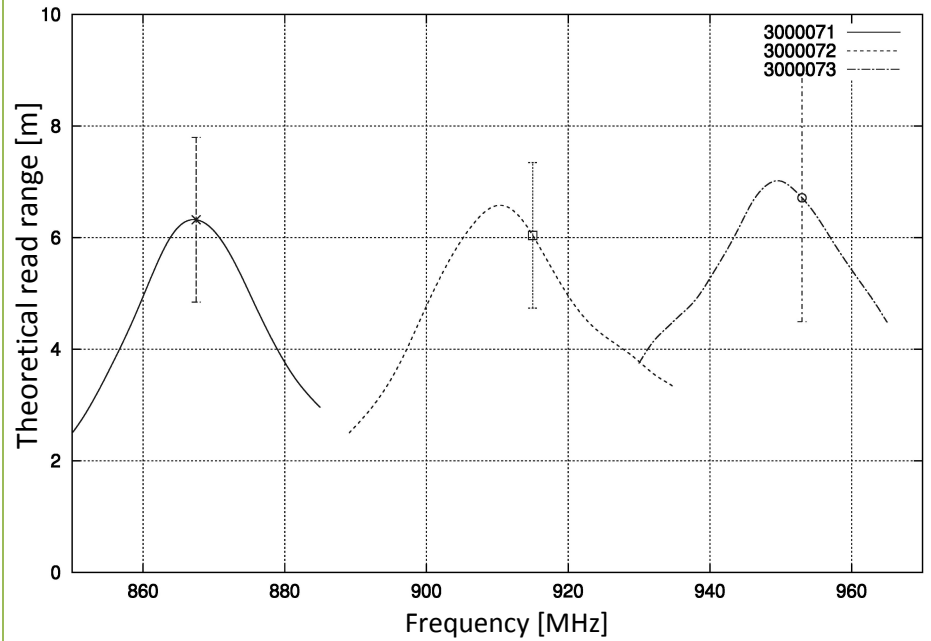

* Read ranges are theoretical values that are calculated for non-reflective environment, in where antennas with optimum directivity are used with maximum allowed operating power according to ETSI EN 302 208 (2W ERP). Variation of 3σ from test batch marked in the picture.

Radiation patterns

Estimated radiation pattern when tag orientation towards reader antenna is optimized.

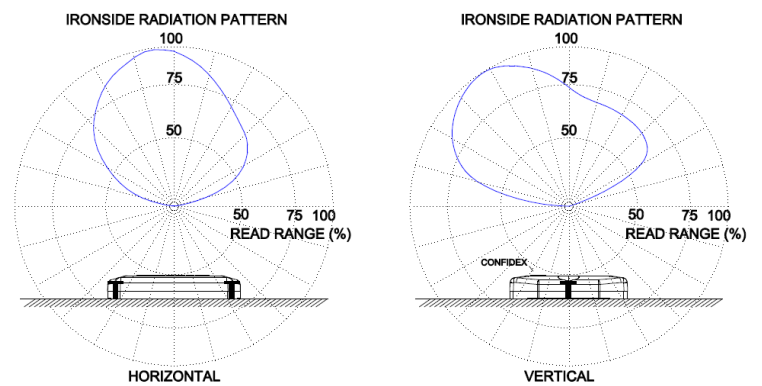

Resistance against environmental conditions*

Typically values are valid for all tag versions. If not, applicable IC versions are marked

Operating temperature	-40°C to +85°C / -40°F to +185°F
Ambient temperature	-55°C to +105°C / -67°F to +221°F @ -55°C / -67°F for 3h
Peak temperature	+125°C / +257°F 1h duration
IP classification	IP68: <ul style="list-style-type: none">- Complete protection against dust- Protection against continuous immersion in water (tested for 5 hours in 1 m [3.3 in] depth)
Weather ability	Good, incl. UV-resistance and sea water
Pressure resistance	170kPa for 10 min
Vibration resistance	Good: <ul style="list-style-type: none">- JESD22-B103B, service condition 2; vibration that is aligned with tag thickness (z-axis).- RTCA DO-160 Rev E 8.5
Operational shock	RTCA DO-160 Rev E 7.2
Chemical resistance	No physical or performance changes in: <ul style="list-style-type: none">- Salt water (salinity 10%, tested in 168h exposure)- NaOH (10%, pH 13, tested in 24h exposure)- Sulfuric acid (10%, pH 2, tested in 168h exposure)- Motor oil (tested in 168h exposure) Generally good against: Methanol (moderate concentrations), ethanol (moderate concentrations), glycerine, ethylene glycol, consistent grease, most acids, bases and tensides such as sulfuric acid 96%, nitric acid 10%, NaOH 50%, soap solution 30%. Testing recommended for hydrocarbons and some of the carboxylic acids. Acetone should be avoided.
Expected lifetime	Years in normal operating conditions

* Values in the table are the best recommendations; resistance against environmental conditions depends on the combination of all influencing factors, exposure duration and chemical concentrations. Thus, product's final suitability for certain environmental conditions is recommended to be tested. Contact Confidex for more specific information.

1.4 Supported components

3M background adhesive

Purpose	High performance adhesive for attaching Ironside on metal surfaces. Suitable for applications without shear forces pointing towards the tag and when tag application is done indoors.
Advantages	Quick and simple attachment method without additional tools
Size	Die-cut according to the tag shape
Type	3M 300LSE High performance acrylic adhesive
Delivery format	Attached to the tag
Minimum order quantity	10 000 pcs

Ironside welding bracket

Purpose	Welding bracket for fixing Ironside on metal surfaces with spot welding.
Advantages	No need to make holes to the surface like with other

	mechanical attachment methods
Dimensions	91.8 x 49.5 mm / 3.61 x 1.95 in
Thickness when tag attached	18.5 mm / 0.73 in
Mechanical picture	
Material	Stainless steel
Weight	39g (when attached to the tag)
Delivery format	Attached to the tag with two pop rivets
Minimum order quantity	10 000 pcs

1.5 Supported services

Standard customer personalization

Either one or several personalization options can be selected.

Encoding	- Unique number <i>Default in the tags</i>	Unique number is programmed to IC EPC memory bank
	- EPC encoding	Customer specific EPC code can be programmed to IC EPC memory bank
Visual marking	- Tampo printing	Same customer specific image or data is printed on top of the all tags.
	- Laser engraving	Variable customer specific data can be engraved on the tag. Maximum character amount 24, can contain numbers and letters.
	- Pair packing	Tags delivered in pairs
Minimum order quantity		10 000 pcs for standard customer specific personalization

1.6 Possible applications

Metal surfaces	Metal returnable transit items, metal containers, metal pallets, high value items, aerospace applications, train wagons, etc.
-----------------------	---

2 Installation instructions

2.1 Tag placement

Ironside tag polarization is perpendicular to the Confidex text. In order to achieve the optimum performance Ironside must be placed on metal surface without covering its front side.

When selecting the location on metal surface, ensure the following:

- Select an even surface so that there is direct metal contact underneath the whole tag.
- The metal background should be preferably as large as possible and tag should be placed in the middle of the surface.
- If surface is small or tag should be installed to the surface edge, install the tag in such way that **most free metal area is left on top of the tag** (see picture on the right side).



Example:

In the two pictures below a small horizontal metal part is shown. First picture shows better and recommended placement for Ironside; free metal area is left on top of the tag (in this case on the left side) which will enhance tag's RF performance. Below placement is not recommended if maximum tag performance should be reached. Note, polarization direction is varying when rotating the tag (see arrows in the pictures).

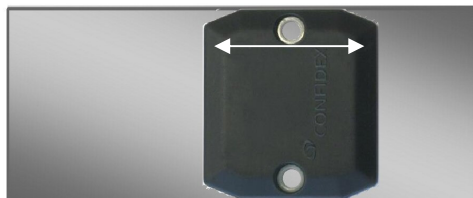

Recommended

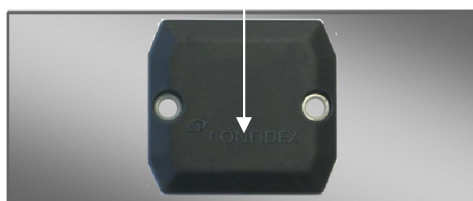

Not recommended

2.2 Tag fixing methods

Mechanical fixing

Mechanical fixing ensures the best and most reliable grip in various use conditions. It's recommended to be used in every application that includes risk for high mechanical stress or low temperature during tag fixing. Ironside tag can be attached mechanically with:

- Screws (size M4)
- Pop rivets (size 4 mm)

Procedure: When fixing the tag with screw or rivets, start by drilling two holes on the surface 40mm apart from each other and fix the tag.

During fixing, make sure that there's no air gap left in between the tag and metal surface.

Adhesive fixing

- Silicone sealants
- 3M 300LSE acrylic adhesive

Silicone sealant adhesives like Dow Corning AS 7096 provide very high bond strength and resistance against mechanical stress. Usually, fixing must be done indoors in room temperature and in 50% humidity. Total curing time can be several days.

Procedure: When fixing the tag with sealant adhesive, insert a layer of sealant under the tag and press the tag on the surface. Increase the bond by adding extra sealant from the tag holes. **Insert max. 3mm layer of sealant under the tag and to the tag holes.**

Please refer silicone sealant supplier for exact product specifications.

3M adhesive: When mounting the tag with its adhesive background, clean and dry the surface for obtaining the maximum bond strength. Remove the liner and place the tag on the correct location. Ideal application temperature is from +21°C to +38°C (+70°F to +100°F), bond strength can be improved with firm application pressure and moderate heating from +38°C to +54°C (+100°F to +130°F). Application at temperatures below 10°C (50°F) is not recommended.

Additional fixing tools

- Welding bracket

When the application is too demanding for adhesives, but the metal surface can not be punched for screw or rivet fixing, welding the tag with special bracket is an option for attachment.

Procedure: Welding bracket will be spot welded on the metal surface. Dimples in the design will ease the welding. Tag is usually riveted to the bracket in advance so the bracket is ready to be used. Bracket design allows attachment on both flat and curved surfaces.

3 Order information

Product number	Product name
3000071	Ironside ETSI NXP G2XM
3000072	Ironside FCC NXP G2XM
3000073	Ironside JPN NXP G2XM

For additional information and technical support contact Confidex Ltd.

FINLAND

Confidex Oy Ltd.
Haarlankatu 1, 33230 Tampere, Finland
Tel. +358 10 4244 100 Fax. +358 10 4244 110
contact@confidex.fi www.confidex.fi

USA

Confidex Inc.
1502 Fair Weather Ct., Apex, NC 27523, USA
Tel. +1 919 349 5607 fax +1 810 958 0515
www.confidex.net

CHINA

Confidex China
Guangzhou XinTag Electronics Science and Technology Co. Ltd
3 F Section E Guangzhou Technology Innovation Base
No. 80 Lan Yue Road, Science City, PRC 510663 Guangzhou,
People's Republic of China
Tel. +86 20 3205 7361 fax +86 20 3205 1429
www.confidex.net.cn

DISCLAIMER

THE MATERIALS, PRODUCTS AND SERVICES ARE SOLD SUBJECT TO ITS STANDARD CONDITIONS OF SALE, WHICH ARE INCLUDED IN THE APPLICABLE DISTRIBUTOR OR OTHER SALES AGREEMENT. ALTHOUGH ANY INFORMATION, RECOMMENDATIONS, OR ADVICE CONTAINED HEREIN IS GIVEN IN GOOD FAITH, CONFIDEX MAKES NO WARRANTY OR GUARANTEE, EXPRESS OR IMPLIED, (i) THAT THE RESULTS DESCRIBED HEREIN WILL BE OBTAINED UNDER END-USE CONDITIONS, OR (ii) AS TO THE EFFECTIVENESS OR SAFETY OF ANY DESIGN INCORPORATING ITS PRODUCTS, MATERIALS, SERVICES, RECOMMENDATIONS OR ADVICE. EXCEPT AS PROVIDED IN CONFIDEX STANDARD CONDITIONS OF SALE, CONFIDEX AND ITS REPRESENTATIVES SHALL IN NO EVENT BE RESPONSIBLE FOR ANY LOSS RESULTING FROM ANY USE OF ITS MATERIALS, PRODUCTS OR SERVICES DESCRIBED HEREIN.

Each user bears full responsibility for making its own determination as to the suitability of Confidex products, materials, services, recommendations, or advice for its own particular use. Each user must identify and perform all tests and analyses necessary to assure that its finished systems incorporating Confidex products, materials, or services will be safe and suitable for use under end-use conditions.

Nothing in this or any other document, nor any oral recommendation or advice, shall be deemed to alter, vary, supersede, or waive any provision of this Disclaimer, unless any such modification is specifically agreed to in a writing signed by Confidex.